

FPGA Platform with DSP capabilities for industrial and educational Applications-1

FPDA-1

J. Boutsen, V. Claes, P. Hilven, K. Stevens, F. Appaerts

XIOS Hogeschool Limburg, Universitaire Campus, Agoralaan, Gebouw H, B-3590 Diepenbeek, Belgium

Futher information: jan.boutsen@xios.be ; vincent.claes@xios.be ; patrick.hilven@xios.be ; kenny.stevens@xios.be ; frank.appaerts@xios.be

Introduction

For our subsections within electronics it is important to examine new techniques and to update our knowledge in the domain of FPGA (Field Programming Gate Array) embedded system development. The aim of our FPDA project is to find out in practice which developing environments are suitable at this moment in order to develop an FPGA embedded system in a very short span of time and make it ready for production. With this project we expect a more intensive interaction to grow between our institutes for higher education, knowledge centres and Flemish small and medium-sized companies, already active or wanting to be so in the field of hardware and software development for FPGA embedded systems. This project is backed up by a multidisciplinary team with a combined know-how and experience in electronics design, programmable logics and system software.

Research

Development flow for FPGA

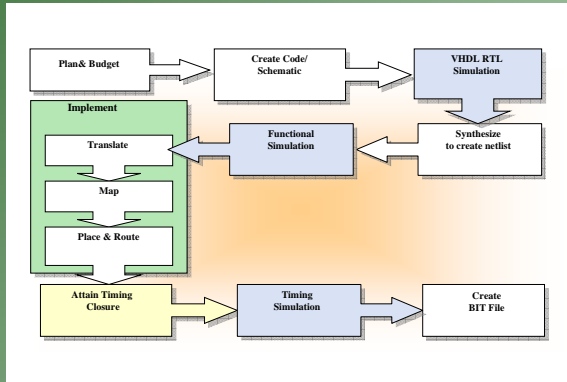

HDL development platform

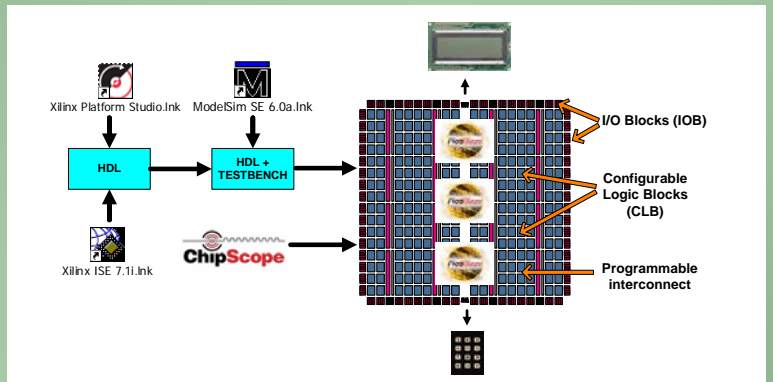

Mathworks development platform

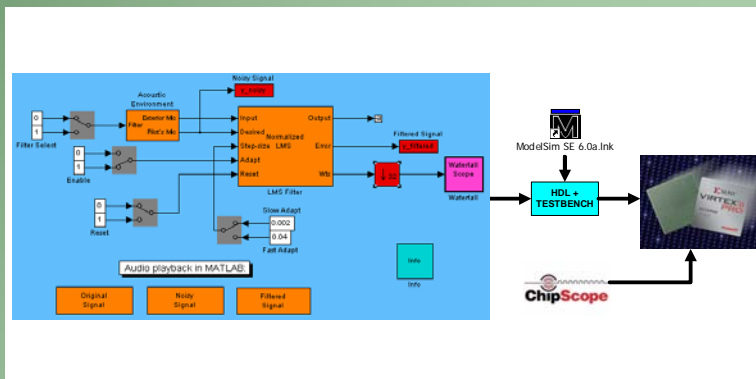

Mixed-Signal development platform

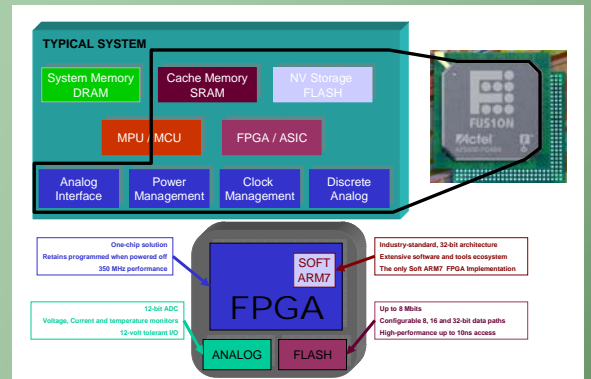

Evolution of Embedded system platforms

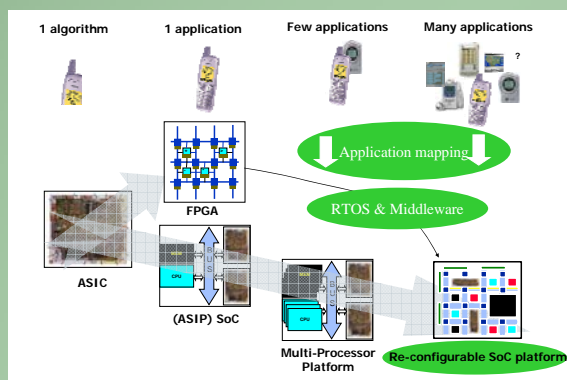

LabVIEW development platform

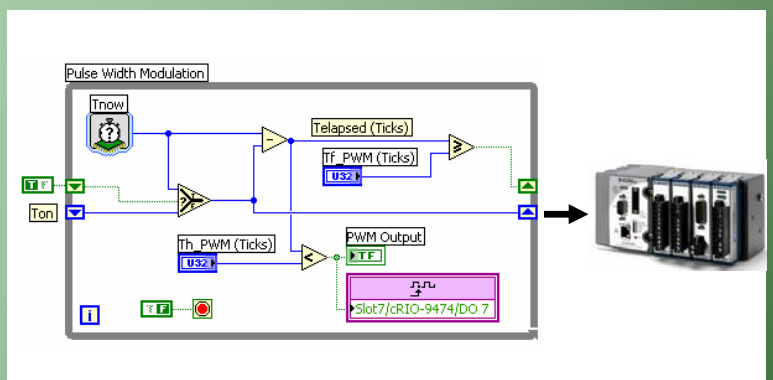

Conclusion

There is a wide offer of developing environments nowadays for an FPGA Embedded system. Unlike some years ago when there used to be quite a range of developing environments with software and hardware components of their own, this market now rather seems to focus on generating hardware-independent and synthesizable HDL. Graphic developing environments are increasing in scope so much so that the 'developer' need not be a software or hardware specialist at all. The result of this trend is that companies wanting to use an FPGA as an embedded system are likely to overcome their initial hesitation. Despite this positive evolution we have noticed, throughout our research, some less favourable tendencies on behalf of the developer. Mutual exchangeability between developing environments of different manufacturers is not quite unproblematic. New software versions and service packs succeed one another as quickly as lightning. The usage of FPGA as an Embedded system and the graphic developing environment presented for that purpose enable the software and hardware developers to market a reliable product within a short lapse of time.